

An Updated Concept for a Generalized Intelligent Framework for Tutoring (GIFT)

Robert A. Sottolare, Ph.D., Keith W. Brawner, Ph.D., Anne M. Sinatra, Ph.D. & Joan H. Johnston, Ph.D.
US Army Research Laboratory – Human Research & Engineering Directorate (ARL-HRED)
Learning in Intelligent Tutoring Environments (LITE) Lab
Center for Adaptive Instructional Sciences (CAIS)

INTRODUCTION

The purpose of this document is to provide users of the Generalized Intelligent Framework for Tutoring (GIFT) with a fundamental understanding of the function, goals/challenges, and research activities associated with the development of a largely domain-independent adaptive instructional capability for the US Army. While the design team for GIFT imagines capabilities beyond military training, the focus of our research is to solve the hard problems and break through barriers to the adoption of adaptive instruction as a practical tool for guiding military training. Adaptive instruction delivers content, offers feedback, and intervenes with learners based on tailored strategies and tactics with the goal of optimizing learning, performance, retention, and transfer of skills for both individual learners and teams. As of this year (2017) the concept that developed into the initial GIFT capability is five years old. So much has been accomplished over the last five years that the team saw the need to update the original GIFT concept document ([Sottolare, Brawner, Goldberg, & Holden, 2012](#)) by discussing research goals and their relationship to military requirements. The remainder of this introduction will focus on military motivation, tools to evaluate the effectiveness of candidate adaptive instructional technologies prior to integration in GIFT, and the economic motivation for a GIFT.

Military Motivation for a GIFT

The US Army Learning Model (ALM; [U.S. Army Training & Doctrine Command, 2011](#)) notes that training and education tools and methods must be of sufficient intelligence to understand and adapt to the needs of individual learners and teams to mitigate negative learner states, and to guide/tailor instruction in real time to optimize learning, performance, retention, and transfer of skills from instruction to operations. This is the basis of self-regulated learning (SRL) where Soldiers are expected to largely manage their own learning and career development through the systematic growth of metacognitive skills (e.g., reflection), self-assessment abilities, and motivational skills ([Butler and Winne, 1995](#)) with guidance from artificially-intelligent software-based agents. While SRL skills are difficult to train and develop, support may be provided to the learner through “adaptive training technologies” (tools and methods), which may be focused to guide learning and reinforce SRL principles.

This emphasis on SRL in a military context highlights a requirement for point-of-need instruction in environments where human tutors are either unavailable or impractical (e.g., mobile/distance learning or microlearning opportunities). The North Atlantic Treaty Organization (NATO) Training Group’s (NTG) working group on Individual Training and Educational Development (IT&ED) found substantial instructional efficiencies in terms of both reduced costs and enhanced effectiveness to be achievable through the use of computer technology. Based on these findings and findings in the literature about the potential effect of Intelligent Tutoring Systems (ITSs), the NATO Human Factors & Medicine (HFM) Panel approved the charter for Research Task Group (RTG) 237 to further investigate the nature, extent, availability, and feasibility of opportunities presented by ITSs for conducting NATO education and training. Dr. Robert Sottolare, US Army Research Laboratory (ARL) co-chaired this RTG and significantly influenced its scope and findings. Key RTG membership included participants from US service

laboratories (ARL, Office of Naval Research, and the Air Force Research Laboratory), Defence Research & Development Canada, Defence Science & Technology Laboratory (United Kingdom), Fraunhofer - FKIE (Germany), National Aerospace Laboratory (Netherlands), and the Gajon Institute of Technology (Italy) . RTG 237 completed its mission in late 2016 and presented its findings for publication to HFM Panel and the NATO Science & Technology Organization (STO). As of the publication of this concept paper, RTG 237's final report is projected to be publicly available during the Summer of 2017. The scope and opportunities identified by RTG 237 point to the high potential of adaptive instruction as a military training and education tool for individuals in the near (1-3 years) to mid term, and for teams in the midterm (3-7 years). To be practical, adaptive instructional tools and methods must be able to represent and adapt training and education in military domains. They must also be sensible alternatives to existing training methods (e.g., effective, affordable, easy to access and easy to use).

Effectiveness, Affordability, and Usability of a GIFT

While the need for adaptive instruction is well-documented, there are several barriers to its adoption as a practical tool for military instruction. The ability to extend ITS architectures to support the training of military tasks and education of military principles is a significant effort, but the critical measures which will determine their adoption are their effectiveness, affordability and usability.

The high potential of ITSs in non-military domains have sustained the thought that they could have the same effect in military domains. Most of these effects concerned memorization, understanding, and application of relatively straightforward facts, concepts, and procedures as early reported by [Vinsonhaler and Bass \(1972\)](#). These findings were later confirmed by [Kulik \(1994\)](#), who surveyed 97 studies of fundamental computer-based instruction effectiveness for his meta-analysis and found an average effect size of 0.32 standard deviations (σ) for computer-based tutoring, which is roughly equivalent to novice human tutoring.

While [VanLehn \(2011\)](#) noted that ITSs were as effective as expert human tutors in well-defined domains (e.g., mathematics, software programming, and physics), they have rarely been employed to support military training or educational domains prior to 2011. ARL began examining the capabilities needed, associated goals/challenges, and the research required to realize an adaptive instructional capability for military task domains (e.g., land navigation, marksmanship, hemorrhage control, and squad-level tasks). This activity provided the impetus for the creation of GIFT in 2012 and in particular the development of a GIFT testbed or construct to support effectiveness evaluations. Everything in GIFT should have a basis in best practice either as defined by the literature or through experimentation.

Adaptive instructional systems by their nature require more content than non-adaptive systems. The associated creation/curation and application of content to adaptive courses requires more effort and skill than in non-adaptive courses. The modeling of learners to ascertain their states include the integration of sensors and classification techniques which are not required in non-adaptive systems. During authoring it can be tedious to create a large number of scenarios necessary to adapt to all the human variations that influence learning. ITSs can be made more affordable by: 1) automating authoring and integration processes, 2) lowering the skills and knowledge required to author, and 3) improving the usability of authoring tools.

Finally, we discuss the usability of GIFT and related tools. In examining the likely population of GIFT users, we determined that the skills required to use the tools should be tightly coupled with the roles and responsibilities of the users. In other words, the authoring tools should be compatible with the authors' mental models of the authoring process. No effort should be wasted searching and no steps should be expected other than those needed to produce an ITS. The ability to develop ITSs in complex

domains should be revealed to the author after they demonstrate authoring skills and understanding of fundamental authoring processes. The next section reviews some of the critical design principles on which GIFT is based.

GIFT DESIGN PRINCIPLES

This section of the GIFT concept paper reviews some of the guiding principles of design that reinforce the effectiveness, military relevance, and affordability of a GIFT. The methodology for the development of a modular, computer-based tutoring framework for military training and education considered enabling design goals, as well as anticipated uses and applications. The design process also considered enhancing one-to-one (individual) and one-to-many (collective or team) training experiences beyond the state of practice for computer-based training (CBT) and ITSs. A significant focus of the GIFT design was to concentrate domain-dependent elements in the domain module of the ITS. This was done to allow large scale reuse of the remaining GIFT components or modules across different instructional domains and thereby reduce ITS development time and cost and promote reuse.

Another design principle adopted in GIFT is that each module (primarily the learner, sensor, pedagogical, domain modules) should be capable of gathering information from other modules according to the design specification. Implementing this design principle resulted in standard message sets and message transmission rules (i.e., request-driven, event-driven or periodic transmissions). For instance, the pedagogical module is capable of receiving information from the learner module to develop courses of action for future instructional content to be displayed, to manage flow and challenge level, and to select appropriate feedback. Changes to the learner's state (e.g., engagement, motivation, affect, or performance) triggers messages to the pedagogical module which then recommends generalized instructional strategies (e.g., ask a question or prompt the learner for more information) to the domain module which provides a domain-specific action or tactic (e.g., what is the next step?).

Another design principle adopted within GIFT is the separation of content from the executable code ([Patil & Abraham, 2010](#)). Data and data structures are placed within models and libraries, while software processes are programmed into interoperable modules. Additional design considerations were given to efficiency and effectiveness goals (e.g., accelerated learning and enhanced retention) for training and education given the limited time available for military training and renewed emphasis on self-regulated learning.

Initially, these design principles were created with the anticipation of adapting the existing design or extending it through expert workshops focused on each of the major adaptive instructional research vectors (individual learner modeling, instructional management, authoring tools, domain modeling, assessment methods, team modeling and instruction, effectiveness evaluation methods, and architecture & ontology). As each of these expert workshops has been conducted, their output has been captured in volumes of the "design recommendation for ITSs" book series as listed below. These books are freely downloadable at www.GIFTtutoring.org and on Google Play.

- Sottolare, R., Graesser, A., Hu, X. & Holden, H. (Eds; 2013). Design Recommendations for Intelligent Tutoring Systems: Volume 1 - Learner Modeling. *U.S. Army Research Laboratory*, Orlando, Florida. ISBN: 978-0-9893923-3.
- Sottolare, R., Graesser, A., Hu, X. & Goldberg, B. (Eds.; 2014). Design Recommendations for Intelligent Tutoring Systems: Volume 2 - Instructional Management. *U.S. Army Research Laboratory*, Orlando, Florida. ISBN: 978-0-9893923-0-3.
- Sottolare, R., Graesser, A., Hu, X. & Brawner, K. (Eds.). (2015). Design Recommendations for Intelligent Tutoring Systems: Volume 3 - Authoring Tools & Expert Modeling Techniques. *U.S. Army Research Laboratory*, Orlando, Florida. ISBN: 978-0-9893923-7-2.

- Sottolare, R., Graesser, A., Hu, X., Nye, B., Olney, A., & Sinatra, A. (Eds.; 2016). Design Recommendations for Intelligent Tutoring Systems: Volume 4 – Domain Modeling. *U.S. Army Research Laboratory*, Orlando, Florida. ISBN: 978-0-9893923-9-6.
- Sottolare, R., Graesser, A., Hu, X., & Goodwin, G. (Eds.; 2017; *in press*). Design Recommendations for Intelligent Tutoring Systems: Volume 5 – Assessment Methods. *U.S. Army Research Laboratory*, Orlando, Florida. ISBN: TBD.

HOW GIFT-BASED TUTORS WORK

A framework like GIFT is often referred to as a “shell tutor” (Goodkovsky, 1996), however GIFT goes beyond the functionality of the traditional shell tutor. Unlike typical shell tutors which focus on one domain and can provide a large number of problem sets, GIFT is a tutoring architecture that can support the authoring of ITSs, the delivery and management of adaptive instruction, and the evaluation of ITSs and adaptive instructional capabilities for nearly any task domain (e.g., cognitive, affective, psychomotor, social).

For most ITSs, there is a general interaction between the tutor, the learner(s) and some type of environment (e.g., training simulation, physics problem set, webpage, slide presentation or serious game). GIFT has been used to generate prototype tutors in cognitive, psychomotor, and small team task domains and its tutors have been linked to external training environments (e.g., simulations or serious games) to form adaptive instructional systems (Figure 1).

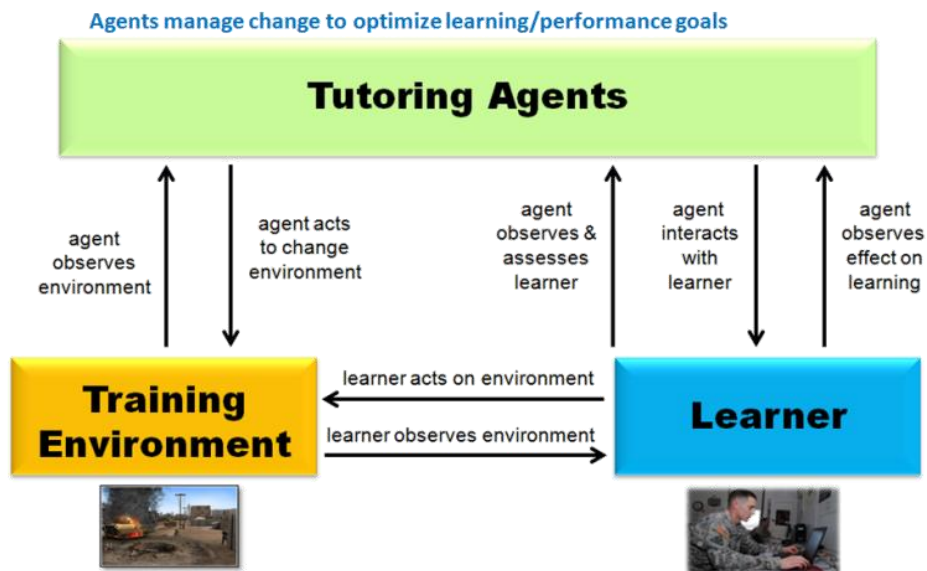

Figure 1. Adaptive Interaction between an ITS (tutoring agents), an Individual Learner and a Training Environment

The tutoring process in GIFT: the flow of information and interaction between the learner, the ITS, and an external environment is illustrated in a more detailed flow in Figure 2. Typical of most ITSs, there is a model of the learner, the instruction, and the domain along with interfaces between the tutor and the learner, and the tutor and an external environment (optional). In GIFT, we refer to these tutoring building blocks as modules because they contain both models and software to act on data received by that building block.

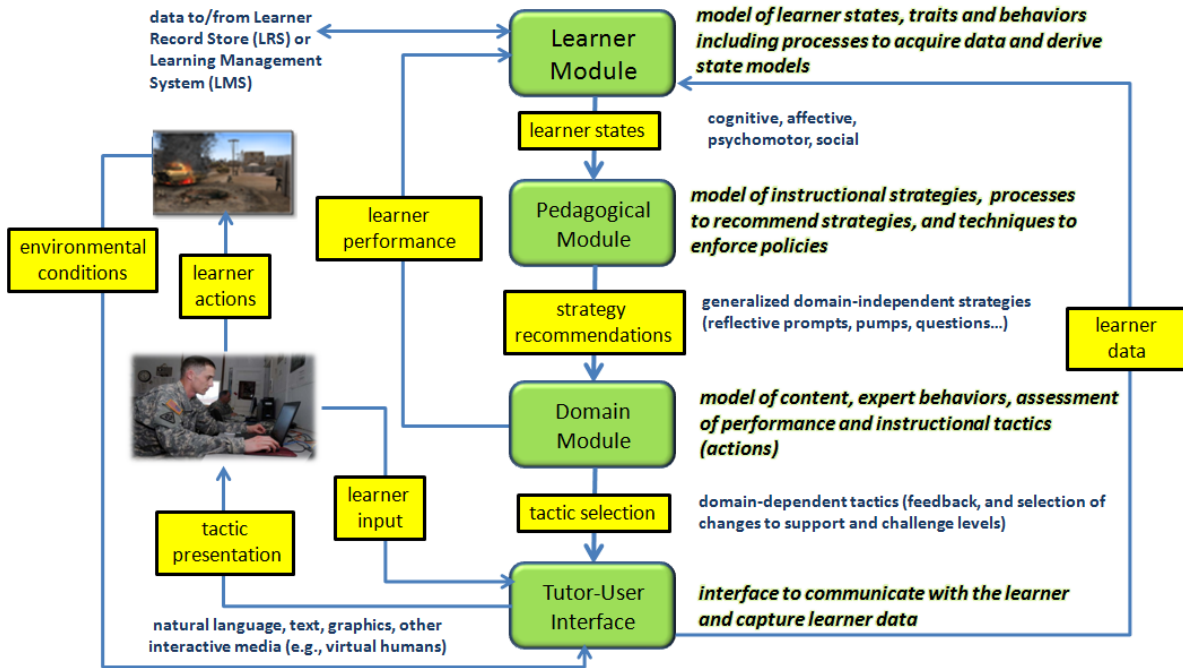

Figure 2. Adaptive Interaction between ITS Components, Individual Learner(s) and External Environments

The terms used for GIFT are similar to the terms used for most other ITSs, with the exception that GIFT refers to the instructional model as the pedagogical module. However, unlike most ITSs, GIFT-based tutors provide some common data fields in the learner module, and rules for instruction which are domain-independent strategies or plans for action. This means these best instructional practices (e.g., error sensitive feedback, mastery learning, asking the learner to reflect, provide a hint to the learner, or prompt the learner for information) can be reused across task domains and the authoring of GIFT ITSs require less effort. The methods of modeling the learner, modeling the instruction, processing sensor data, designing virtual character interactions, and other items do not need to change in support of a new training domain. Similarly, a new content model isn't needed in order to test a new learner model.

When examining GIFT as a testbed for experimentation, we refer to two models which illustrate how ARL uses GIFT to measure the learning effect of capabilities in GIFT. In Figure 3, we show the first model as the interaction of a single learner in the adaptive instructional process and in Figure 4, we show the second model as the interaction of a team of learners in the adaptive instructional process. This model of experimentation has come to be known as the learning effect model (LEM; Sottolare et al., 2017, *in review*).

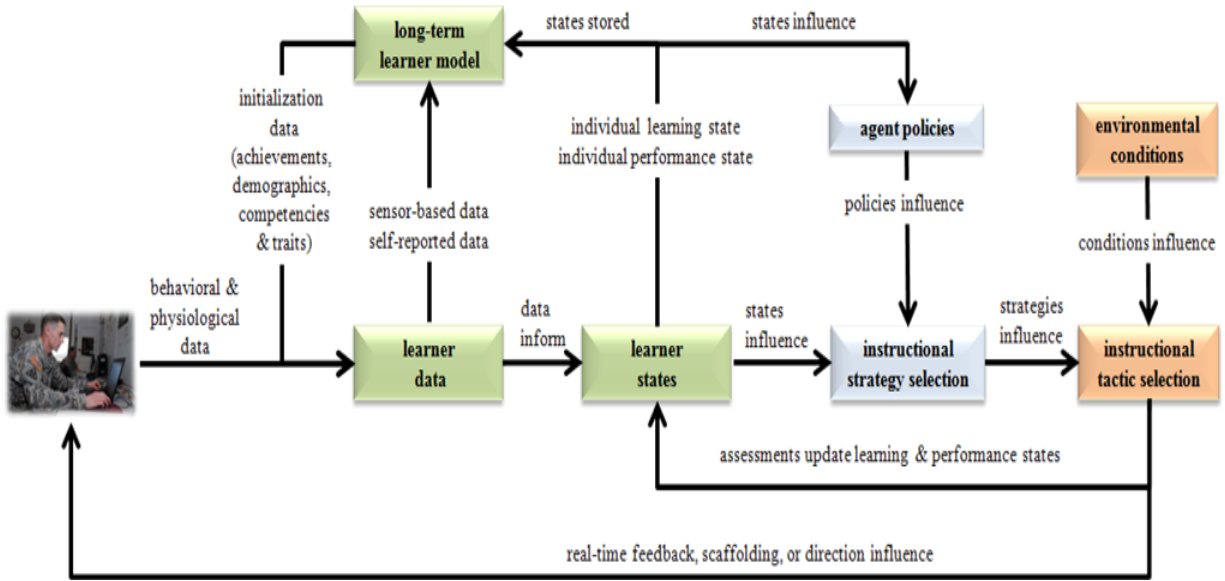

Figure 3. Learning Effect Model (LEM) for Individuals

In the green boxes in Figure 3, the LEM for individual learners shows short (real-time data acquisition and state classification) and long term learner modeling (record of learner states and achievements). The light blue boxes show domain-independent instructional strategies (plans for action) and policies (e.g., mastery learning or error-sensitive feedback) which must be enforced by the ITS. The orange boxes show domain-dependent states (environmental conditions) and tactics (ITS actions based on recommended strategies and policies).

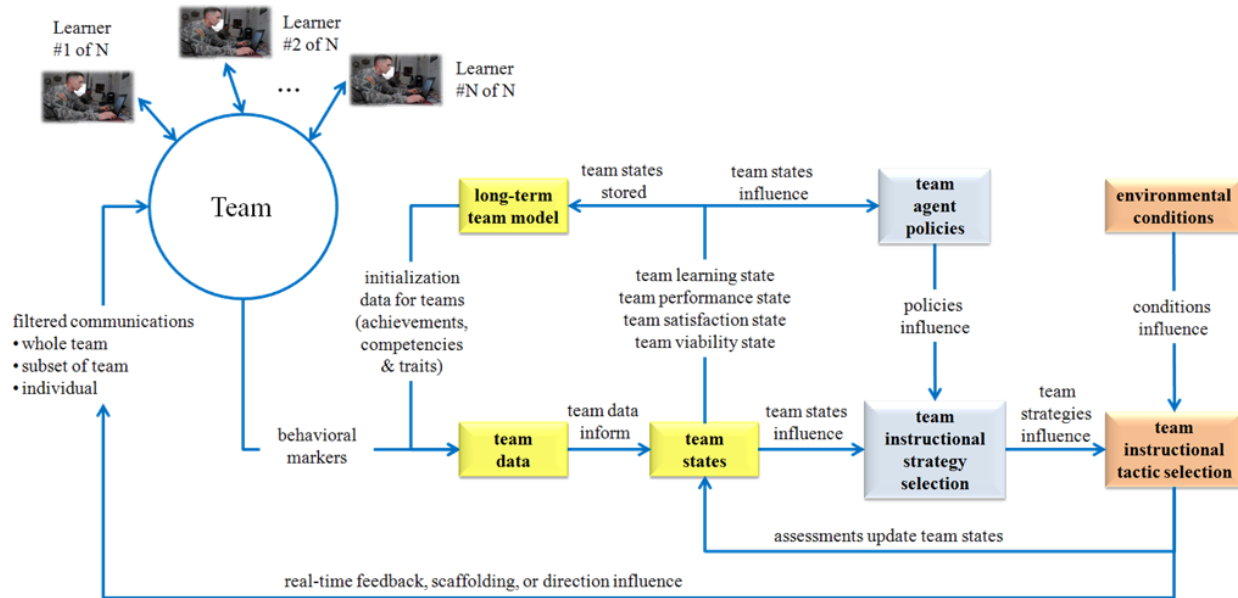

Figure 4. Learning Effect Model (LEM) for Teams

In the yellow boxes in Figure 3, the LEM for teams shows short (real-time data acquisition and state classification for teamwork and taskwork) and long term team modeling (record of team states and achievements). Just as in the LEM for individuals, the light blue boxes show domain-independent

instructional strategies (plans for action) and policies (e.g., mastery learning or error-sensitive feedback) which must be enforced by the ITS. The orange boxes show domain-dependent states (environmental conditions) and tactics (ITS actions based on recommended strategies and policies).

The following subsections focus on the functional elements of GIFT, modules, which not only provide models of the learner, the instruction, and the domain, but also functionally act on data shared between them.

GIFT Messages

GIFT incorporates a service-oriented architecture (SOA) to support distributed training and mobile learning contexts which extend ITSs beyond the traditional one-to-one tutoring contexts to support collaborative and team instruction. Tutoring processes (e.g., acquisition of learner data via sensors, learner state assessment, and content presentation decisions) must be able to support tutoring processes in remote locations (e.g., cloud-based tutoring). For example, an ITS for a mobile learner must support local processes for the sensors used to gather the learner's data, but the learner module that assesses the learner's state may not be local due to the computation limitations of the learner's mobile device.

For each module to interact seamlessly and adapt to new information, a JAVA-based framework has been constructed to facilitate the communication of GIFT modules. The SOA allows GIFT to be expanded by adding new modules and standard messages. GIFT is also able to run on physically separate computers/mobile devices and to be accessed by multiple learners simultaneously to support concurrent training sessions or distributed team training. Messages are JavaScript Object Notation (JSON) encoded. A wrapper for this interface is available in the form of a web-based interface known as the Tutor User Interface (TUI), which serves as a front end for GIFT users.

The GIFT design allows each module to run as a separate process to be independent of the computer programming language. The tradeoff of this design decision is that each module must conform to a shared standard. The standard performs the function of communicating within the framework, and includes functions such as sending, receiving, encoding, and parsing messages. The shared functions are part of an initial library of shared code which is currently written in Java and C++. For module developers to be able to program in other languages this library must be written into other programming languages. At the time of writing, portions of the codebase are written in Java, C++, C#, Javascript, Python, and other languages.

Sensors and the GIFT Sensor Module (domain-independent)

As shown in Figure 5, the sensor module contains a suite of specific sensor interfaces for behavioral and physiological sensors. It accepts raw sensor data and adapts this data into a usable form by a sensor processing module which filters, segments or extracts features in the data. The sensor processing module then transfers the processed data to Learner Module via the messaging backbone. The fact that each sensor used in the architecture is different indicates that there must be an interface and an associated sensor processing module for each sensor used. Since there is an associated processing cost with the implementation of each sensor, it is critical that minimum sets of sensors be identified to determine each cognitive and affective state within different training platforms (e.g., computer-based training, mobile learning).

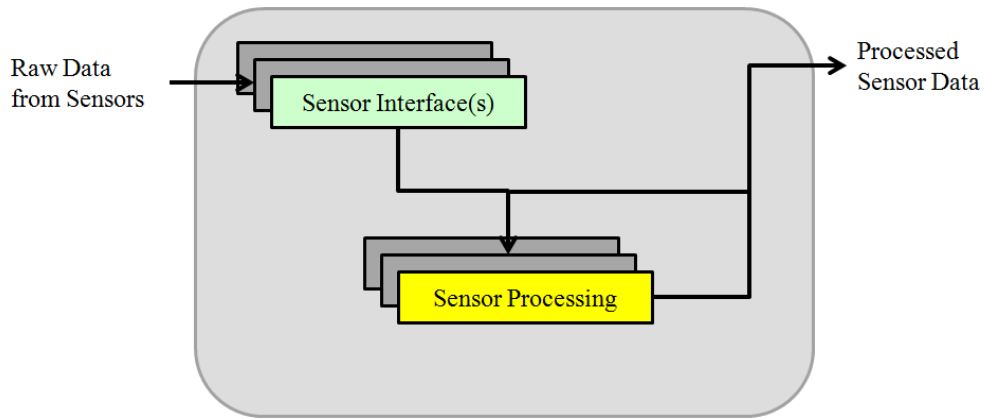

Figure 5: Sensor Module (Domain-Independent)

GIFT Learner Module

The learner module is primarily driven by the learner model. It supports the assessment of the learner's states (e.g., performance, cognitive, affective or physical) based on historical data in a record store (e.g., performance, traits, or preferences) and/or learner inputs (e.g., survey data, interaction data, or sensor data) as shown in Figure 6. The functions of the learner module are the determination the learner's states, tracking relevant learner trait data (e.g., personality preferences) and lesson data (e.g., lesson start/completion, lesson scores or performance), and predicting learner information and trends within the instructional process. The learner module makes use of pre-processed behavioral and physiological data from the sensor module, a performance assessment (e.g., failing to meet, meeting or exceeding expectations), and demographic, self-reported and observed data to classify the learner's states. This learner state data is used by the pedagogical module to determine which content or instructional strategy (e.g., direction, questions, feedback) to present to the learner next.

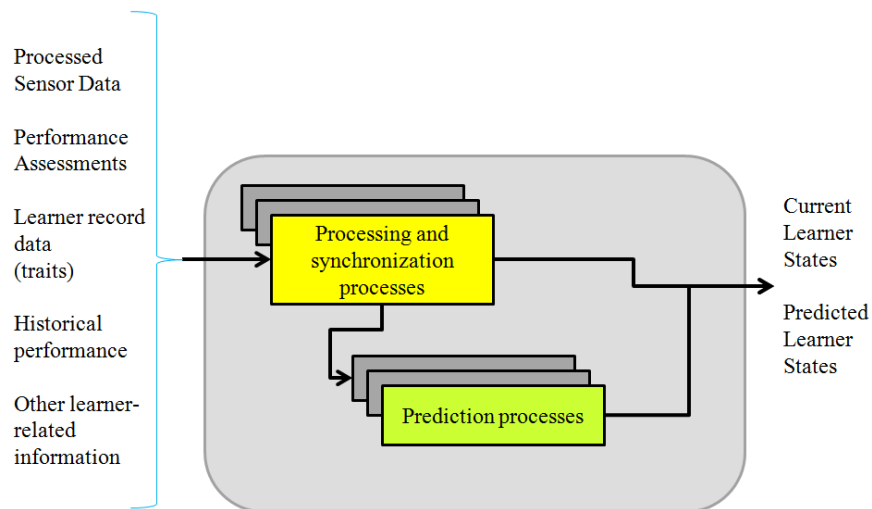

Figure 6: Learner Module (Domain-Independent)

GIFT Pedagogical Module (domain-independent)

In Figure 7, the pedagogical module receives state data from the learner module (learner state). It uses learner state and performance to determine the content, order and flow of instruction. It receives information as to its instructional options from the Domain Module. The question that the pedagogical module is tasked to answer is: “given a learner is in the following state, what is the recommended course of action?” The Domain Module is responsible for translating the generic instruction strategy requests into actions for the learner. Similar to the other Modules, the process for determining which actions to take may vary from model to model (MDP, decision tree, etc.). Pedagogical strategies are in place to make decisions about what to do next when multiple options are available ([Dabbagh, 2005](#)). They can manipulate elements within a training scenario; provide hints or feedback; and change the pace and difficulty of interaction ([Wulfreck, 2009](#)).

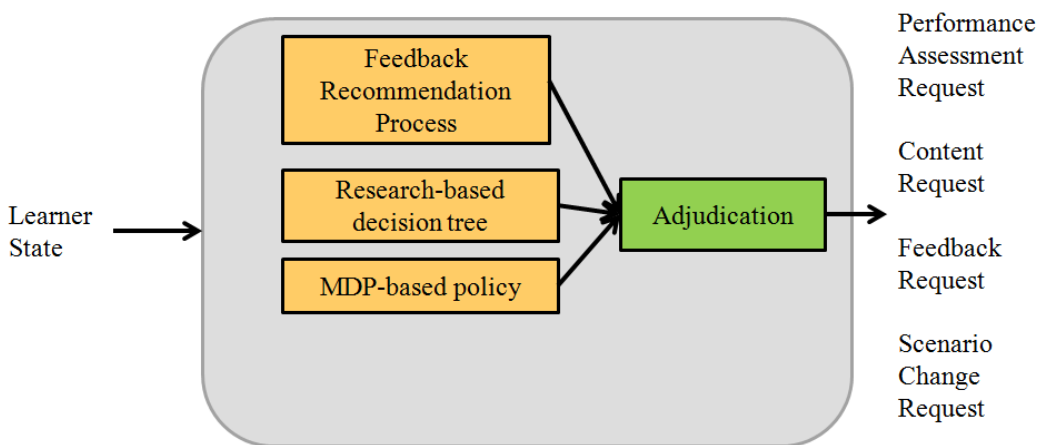

Figure 7: Pedagogical Module (Domain-Independent), example of processes within

GIFT Domain Module (domain-dependent)

The purpose of the domain module is to define and structure domain knowledge (e.g., instructional content, domain-relevant tasks/conditions/standards, problem sets, common questions and common misconceptions). Several standards exist that represent domain knowledge: the Institute of Electrical and Electronics Engineers, Inc. (IEEE) Learning Object Metadata (LOM); Sharable Content Object Reference Model (SCORM) and Instrument and Measurement Society (IMS) content packaging ([Boneu, 2011](#)). GIFT is being designed to interface with any or all of these standards in order to leverage domain-specific content that is compatible with these standards.

In Figure 8, the actions of the domain module are driven by the pedagogical module which recommends generalized strategies (e.g., ask a question, prompt the learner for more information, review basic concepts, etc.) which the domain module converts into specific instructional tactics (e.g. ask a question on concept B, prompt the learner for more information on concept B, or review basic concepts for building clearing tasks). The decisions on which content to present, the order and pace of presentation, and the type of feedback to provide (e.g., supportive, directive hints or questions) is made by the domain module. The domain module also assesses learner actions and progress over a lesson, course or area of study. This is generally accomplished by comparing the correctness of learner responses, and comparing learner performance to expert performance or other standards. By maintaining the learner assessment within the

Domain Module and then only providing the result of the learner assessment to the pedagogical module, the domain-independence of the pedagogical module and other functions within GIFT are maintained.

The Domain Module captures data that is coming out of the training environment (e.g., game or simulator), and assesses performance against key concepts. These assessments are sent out to the Learner Module and compared to previous assessments to determine learning trends. Each of the assessments is labeled as above standard, at standard, below standard, or unknown so that all of the other modules can treat it as if it was any other concept. The concepts that are assessed are parts of tasks and tasks are in turn part of lessons. All task assessments address what is done, the conditions under which the task is done, and the standards or measures under which the task performance is assessed.

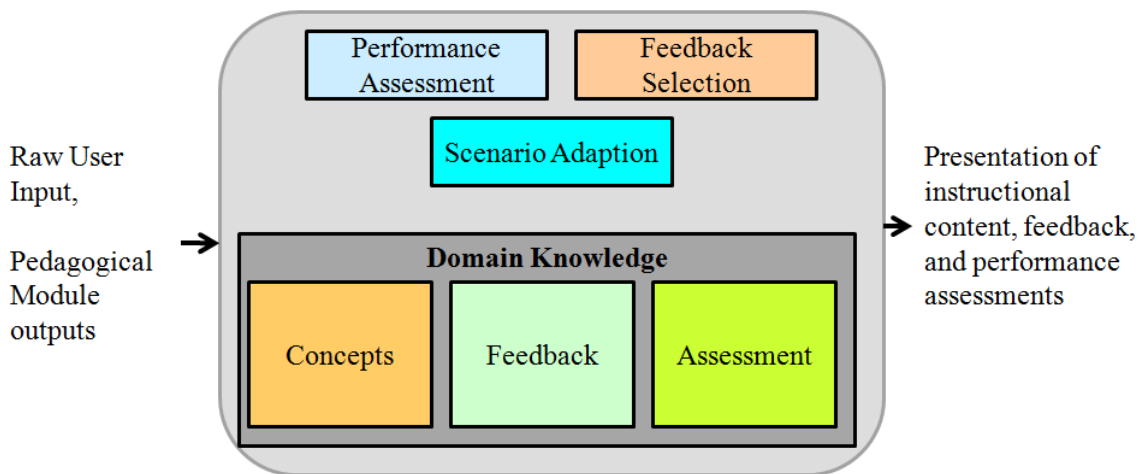

Figure 8: GIFT Domain Module

Training Application Servers, Clients and GIFT Gateways

To leverage external training environments, GIFT has developed gateways to interface multi-media training environments to the SOA using application servers and clients for serious games, simulators, distributed learning environments (e.g., SCORM or Experience API), and virtual human capabilities. To support a higher level of interaction and an adaptive tutoring capability, GIFT has also developed a gateway to integrate presentation-based (e.g., PowerPoint) courses/lessons.

The section that follows delves deeper into adaptive instructional research, and associated goals, challenges, and approaches to solving some of the problems needed to prototype adaptive instructional capabilities. Further, consideration needs to be given for individuals, teams that train/educate in militarily-relevant task domains, as well as whether the domain is high or low density (large populations requiring common skills or small populations with specialized skills).

GIFT FUNCTIONS AND ADAPTIVE INSTRUCTIONAL RESEARCH

In support of an adaptive instructional capability, ARL has clustered several research questions related to meeting the goals and challenges of making ITSs practical for military use and decomposed these into seven research vectors: authoring, individual learner modeling, team (collective) modeling, instructional management, domain modeling, effectiveness evaluations, architecture and ontology. ARL published a

research outline for each of these vectors (except architecture and ontology) in 2015. Each research outline is referenced in the affiliated section below. GIFT was created and continues to grow in capability under the architecture and ontology vector, however, it was decided that the other research vectors should push the evolution of GIFT. In current form, the architecture and ontology vectors focus on making GIFT accessible and efficient. To make ITSs practical for use in military domains, it is necessary to understand several key questions and challenges in each of the seven vectors, which are discussed below.

Authoring

Authoring is the process of gathering, organizing, and sequencing content for delivery to the learner. Part of the authoring process is also identifying learning objectives (also known as concepts in GIFT) and associating content, learner attributes (states and traits), and measures of learning and performance with those learning objectives to allow ITSs to track learner progress. ITSs are expensive because it takes a set of very specific skills and a keen understanding of intricate instructional processes to build them. ITSs are often systems built for a purpose (domain-specific) by teams whose expertise usually includes instructional design, software programming, human factors, and extensive domain knowledge (e.g., subject matter experts). A major goal for GIFT is to support authoring without the need for instructional design, software programming, or human factors knowledge/skills. It is expected that some subject matter knowledge will be required to gather, organize, and apply domain content in GIFT or other ITS architectures.

Until recently, ITSs were still only practical investments in high density domains (e.g., high school algebra) where the expense to build an ITS could be offset by the large number of learners who might pay to use the tutor. The major barrier to adoption of ITSs as instructional tools of choice in military instruction is the time and skill needed to author ITSs. Addressing this barrier involves lowering the cost by reducing the time and skill requirements for authoring ITSs. In this way, ITS technologies can be practical for use even for low density task domains where the number of learners is low. In 2015, [Ososky, Sottolare, Brawner, Long and Graesser](#), outlined three approaches to five authoring goals/challenges. The major challenges to making ITS authoring processes practical and cost effective:

- Decrease the resources (time, cost, etc.) required to author an ITS
- Decrease the skill threshold required by various user groups associated with authoring and managing an ITS
- Enable rapid prototyping of intelligent tutors for rapid design and evaluation of capabilities
- Develop standards, including common tools and interfaces, for tutor authoring
- Promote reuse of content, modules, and data structures in tutors

Below are research approaches to lowering the time and skill required to author ITSs:

- Apply usability heuristics to develop best practices to guide human authoring of ITSs based on the author's role (e.g., domain expert, instructional designer, or course manager)
- Identify elements of the authoring process that are candidates for automated or semi-automated authoring processes to remove the human from the process wherever possible (e.g., automated scenario generation)
- Establish standards for the integration of functionally disparate tools and technologies (e.g., external training systems and serious games) that may be relevant to adaptive systems to reduce the need for authoring by promoting reuse through interoperability

To learn more about GIFT and specifically authoring tools, we recommend downloading and reading the following at www.GIFTtutoring.org:

- Design Recommendations for Intelligent Tutoring Systems – Volume 3: Authoring Tools & Expert Modeling Techniques (<https://gifttutoring.org/documents/56>)
- GIFT Quickstart Guide (<https://gifttutoring.org/documents/69>)

Individual Learner Modeling

GIFT is a learner-centric system in that the ITSs produced by GIFT make instructional decisions based largely on the states/traits of the learner with the goal of benefitting the learner by enhancing learning, performance, retention, and the transfer of skills from instruction to operations. In 2015, [Goodwin et al.](#) documented goals/challenges and approaches to acquiring data about the individual learner or team (e.g., via historical records, sensors, self-report mechanisms, or during reflective dialogues) and then classifying/predicting individual or team states (e.g., performance or emotions) based on the available data. In 2016, ARL decided that these modeling problems were sufficiently different to merit separate attention and thus are addressed separately in this concept document, and in the research vectors. The remainder of this section will focus on individual learner modeling.

There are several individual attributes (states or traits) on which GIFT and other ITSs might adapt instruction, but GIFT’s default instructional policy, the engine for Managing Adaptive Pedagogy (eMAP) currently adapts instruction based on:

- *goal orientation* - the degree to which a learner or team focuses on tasks and the end results of those tasks (e.g., mastery, performance/achievement)
- *grit* – (also known as resilience or perseverance) a theoretical construct used to predict learner behavior when faced with difficulties or obstacles to learning; may be measured through validated instruments (surveys)
- *motivational level* - a theoretical construct used to predict learner behavior during adaptive instruction and the reason for learner actions, desires, beliefs, needs, and intentions
- *knowledge or skill level* – measures of previous learning or competence used to predict proficiency in accomplishing a future task; knowledge may be assessed with a pretest in GIFT to determine a starting point for new learning experiences
- *self-regulatory ability* - ability to monitor and control our own behavior, emotions, or thoughts, altering them in accordance with the demands of the situation; sometimes referred to as “emotional intelligence”

To support acquisition of individual learner data to determine real-time learner states, ARL has integrated a set of sensors into GIFT over the last five years to support experimentation. The GIFT user community should benefit from the integration of future commercial sensors. As a group, these sensors allow GIFT to assess learner states that include: engagement, motivation, anxiety, and engaged concentration. The inclusion of these sensors in the list below should NOT be construed as an endorsement of their capabilities.

- *Zephyr BioHarness* – a physiological sensor that incorporates Bluetooth technology to acquire and transmit heart rate, breathing rate, and 3-axis accelerometer data.
- *Emotiv* – this headset is a wireless electro-encephalogram (EEG) that measures brainwaves.
- *Emotiv EmoComposer* – as part of the Emotiv SDK, emocomposer is an application program interface (API) which enables users to access facial gestures, Emotiv-derived states, Emotiv headset data like the gyro, and trained cognitive actions to allow programmers to use brain activity in their applications.

- *Microsoft Kinect* – a motion sensing input device based around a webcam-style add-on peripheral, it enables users to control and interact with their console/computer without the need for a game controller, through a natural user interface using gestures and spoken commands.
- *Microsoft Band* – an activity tracker/fitness tracker which can be integrated with Windows Phone, iOS, and Android smartphones through a Bluetooth connection; the band features several sensors including: a heart rate monitor, three-axis accelerometer, gyrometer, GPS, microphone, ambient light sensor, galvanic skin response (GSR) sensors, a UV sensor, and a skin temperature sensor.
- *Affectiva Q Sensor* – similar in function to the Microsoft Band
- *Virtual Human Toolkit (VHT) Multisense* - a perception framework that enables multiple sensing and understanding modules to inter-operate simultaneously, broadcasting data through the Perception Markup Language (PML); its main use within the VHT is head and facial tracking through a webcam.
- *Temperature and Humidity Sensitive Mouse* - A custom-made sensor, built into a mouse, which measures temperature and humidity of the palm of the hand.
- *Continuous Self-Assessment Sensor* - An example sensor to which the user can input affective state. The data is labeled (Motivation, Engagement, etc.) as specified in the configuration.

While the sensors discussed above are focused on real-time assessment of learner states, ITSs could greatly benefit from the addition of some long-term learner modeling data to classify/predict learner competency or confidence in their performance. For this reason, GIFT has been enabled to create achievement statements based on the experience Application Program Interface (xAPI) standard. xAPI statements may be generated at various levels of granularity (e.g., at the problem completion level or at the degree completed level) and written out from GIFT to a record store for later use. One particular challenge is to use xAPI statements to automatically predict competency for a learner entering a new learning domain. This information could be used to emphasize learning of concepts where competency is low and skip (or lightly review) concepts where competency is high.

The major goals/challenges for modeling individual learners are:

- Real-time acquisition of physiological and behavioral sensor data for application in machine learning classifiers
- Real-time classification of learner states to support adaptive instructional decisions in complex environments
- Classification of domain competency using long term individual learner data (e.g., achievements, demographics, traits) stored in learning management systems and individual record stores
- Understanding of human variability and how individual attributes influence learning capacity (ability to learn) and learning rate (accelerated learning)
- Maintaining the accuracy of classification methods in environments with data issues (e.g., small samples, missing or ill-defined data) and within complex systems
- Support individual instruction in militarily-relevant individual domains (e.g., marksmanship)
- Lack of capability to handle and process large amounts of structured and unstructured learner data (also referred to as big data)
- Lack of an easily accessible, persistent, cost-effective, and low-overhead training environment for individual learners

Below are research approaches to acquiring learner data and accurately classifying learner states:

- Evaluate the performance of unobtrusive sensors in dependably acquiring learner physiological and behavioral data
- Evaluate the performance (accuracy) of machine learning classifiers for various states related to learning outcomes

- Examine and validate the accuracy of semantic analysis and other classification techniques in classifying/predicting domain competency of learners based on their experiences/achievements
- Examine reinforcement machine learning techniques to continuously improve instructional strategy and tactic selection for individual training and educational experiences
- Examine machine learning techniques for working with small samples, missing data or inaccurate data for individual learners
- Examine opportunities to link GIFT Cloud with external individual training simulations and serious games to provide an easily accessible, persistent, cost-effective, low-overhead training environment for adaptive individual instruction

To learn more about GIFT and specifically learner modeling, we recommend downloading and reading the following at www.GIFTtutoring.org:

- Design Recommendations for Intelligent Tutoring Systems – Volume 1: Learner Modeling (<https://gifttutoring.org/documents/42>)

Team (Collective) Modeling

Currently, there are no tools or methods available in the public baseline for modeling or tutoring teams in GIFT. However, there are research initiatives focused on team modeling, and identification of teamwork and taskwork processes. The major goals/challenges for modeling teams of learners are similar to those for individual learners. In 2015, [Goodwin et al.](#) also documented team modeling goals/challenges and approaches. Identified goals/challenges follow:

- Real-time acquisition of team behavioral measures for application in machine learning classifiers
- Real-time classification of collective taskwork and teamwork states to support adaptive instructional decisions in complex environments
- Classification of team competency using long term individual team member data (e.g., achievements, demographics, traits) stored in learning management systems and individual record stores
- Maintaining the accuracy of classification methods in environments with data issues (e.g., small samples, missing or ill-defined data) and within complex systems
- Support of team instruction in militarily-relevant team task domains (e.g., building clearing, collaborative problem solving)
- Lack of capability to handle and process large amounts of structured and unstructured team data (also referred to as big data)
- Lack of an easily accessible, persistent, cost-effective, and low-overhead training environment for teams of learners

Below are research approaches to acquiring team data and accurately classifying team states:

- Evaluate the performance of unobtrusive sensors in dependably acquiring team behavioral data
- Evaluate the performance (accuracy) of machine learning classifiers for various states related to teamwork and collective taskwork performance
- Examine and validate the accuracy of semantic analysis and other classification techniques in classifying/predicting domain competency of teams based on their collective experiences/achievements
- Examine reinforcement machine learning techniques to continuously improve instructional strategy and tactic selection for team training and educational experiences
- Examine machine learning techniques for working with small samples, missing data or inaccurate data for teams of learners

- Examine opportunities to link GIFT Cloud with external individual training simulations and serious games to provide an easily accessible, persistent, cost-effective, low-overhead training environment for adaptive team instruction

To learn more about GIFT and specifically team tutoring, we recommend downloading and reading the following at www.GIFTtutoring.org:

- Antecedents of Adaptive Collaborative Learning Environments (<https://gifttutoring.org/documents/78>)

Instructional Management

Instructional management is the concept of automatically managing the delivery, pace, and sequencing of instruction. Instructional management includes the assessment and response to changing states of the learner and affiliated training/educational environments. [Goldberg, Sinatra, Sottolare, Moss, and Graesser \(2015\)](#) documented instructional management goals/challenges and approaches. Goals/challenges follow:

- Discover and deliver personalized and adaptive training experiences that are informed by experimentation or prior research on tutoring methods and techniques that are moderated by individual differences of a learner, or team of learners, to promote efficient knowledge and skill acquisition across technology-driven training applications.
- Research, design, and develop prototype authoring tools grounded in learning and instructional theory and informed by empirical research to assist training managers, developers, and subject matter experts (SMEs) in building pedagogically sound training experiences without the requirement of programming.
- Discover and develop modeling functions that account for uncertainty across policies informing pedagogical decisions (e.g., content delivery, course navigation, and guidance) with an ability for these functions to refine and optimize themselves through reinforcement learning mechanisms over time as new interaction and performance data becomes available (e.g., Markov Decision Processes).

Below are research approaches to automatically managing the delivery, pace, sequencing of instruction:

- Examine learning and instructional theories (e.g., [Merrill's Component Display Theory, 1994](#)) to identify best pedagogical practices to optimize learning experiences in GIFT
- Examine opportunities to expand ITS design beyond cognitive domains to additional militarily-relevant domains including psychomotor and social tasks; examine the capabilities and data needed to author, assess, and support instructional decisions in GIFT for new task domains
- Discover methods to enhance learning outcomes over time through data mining
- Model the perception, judgment, and behaviors of expert human tutors to support practical, effective, and affordable learning experiences guided by computer-based agents
- Leverage prior research in the learning sciences and AI communities (both theoretical and empirical) to establish a set of best practices on how to author and execute techniques, strategies, and tactics across any domain of instruction
- Discover and develop modeling functions that account for uncertainty across policies informing pedagogical decisions (e.g., content delivery, course navigation, and guidance)
- Personalize instructional technique and strategy selections based on individual differences informed through empirical evaluations and reinforcement machine learning methods
- Develop authoring tools grounded in cognitive and instructional theory and informed by empirical research to assist training managers, developers, and SMEs in building pedagogically sound training experiences without the requirement of programming

- Support individual and team training (e.g., small unit and collective training) and education (e.g., collaborative learning and problem-solving) experiences

To learn more about GIFT and specifically instructional management, we recommend downloading and reading the following at www.GIFTtutoring.org:

- Design Recommendations for Intelligent Tutoring Systems – Volume 2: Instructional Management (<https://gifttutoring.org/documents/44>)

Domain Modeling

As GIFT has been designed to be largely domain-independent except for in the domain model, the concept of domain modeling is vital. Work in domain modeling strives to make GIFT generalizable for multiple domains, and provide flexibility to facilitate reuse. In [2015, Sottolare, Sinatra, Boyce, and Graesser](#) documented domain modeling goals/challenges and approaches. Goals/challenges follow:

- Understand and model the characteristics, similarities, and differences of military training domains (cognitive, affective, psychomotor, social, and hybrid) with respect to their associated knowledge representations to support more efficient and effective authoring, instruction, and evaluation of adaptive training tools and methods
- Understand and model the dimensions (definition, complexity, and dynamics) of training domain representations to extend the capabilities of traditional ITSs; thereby, supporting challenging, militarily-relevant training domains

Below are research approaches to modeling domain content and dimensions:

- Examine the efforts required to author domains of varying complexity, definition, and physical dynamics and identify methods
- Define methods to measure task domain complexity to allow comparative evaluation of different authoring systems and capabilities
- Examine domains for ill-defined and well-defined tasks to understand differences and support authoring processes for both
- Examine the composition of militarily-relevant training and education domains across the spectrum of cognitive, affective, psychomotor, and social tasks to understand requirements for authoring
- Discover/examine methods to match the nature of military tasks in training/educational environments and operational environments to optimize transfer of skills, and evaluate methods to determine the return on investment (ROI) for high levels of compatibility
- Discover methods to accurately assess learning and domain task performance in real-time
- Discover methods to promote optimal learning, performance, retention and transfer (on-the-job performance) across domains
- Discover tools and methods to support individual and team training (e.g., small unit and collective training) and education (e.g., collaborative learning and problem-solving) experiences

To learn more about GIFT and specifically domain modeling, we recommend downloading and reading the following at www.GIFTtutoring.org:

- Design Recommendations for Intelligent Tutoring Systems – Volume 4: Domain Modeling (<https://gifttutoring.org/documents/105>)

Effectiveness Evaluation Methods

Training effectiveness, or the evaluation of the outcomes of an ITS in regard to learning, performance, retention and transfer is important. While best practices may be followed when an ITS is designed, it is still vital to determine that it has successful outcomes. In [2015, Johnston, et al](#) documented effectiveness goals/challenges and approaches. Goals /challenges follow:

- Understand and model the pretraining, during training, and posttraining assessments and the relationships among them to determine the instructional evaluation factors needed to establish the effectiveness of adaptive tutors.
- Understand and model relevant characteristics of individuals, teams, instructional environments, and organizations to understand their influence on the effectiveness of adaptive instruction before, during, and after instruction.

Below are research approaches to evaluating the effectiveness of adaptive instructional capabilities in GIFT:

- Investigate evidence-centered measures as a source of reliable effectiveness measures
- Discover/adapt tools/instruments to support reliable assessment of individual traits

To learn more about GIFT and specifically effectiveness evaluation tools, we recommend downloading and reading the following at www.GIFTtutoring.org:

- Effectiveness Evaluation Tools and Methods for Adaptive Training and Education in Support of the US Army Learning Model: Research Outline (<https://gifttutoring.org/documents/66>)

CONCLUSION

GIFT is continually being applied to new problem spaces in adaptive tutoring. Through the efforts of the overall GIFT project, and the research vectors, a complex problem has been broken down into achievable pieces. Progress continues to be made in all research areas of GIFT, and it provides a means of reducing the cost, skill, and time needed to create ITSs. The challenges associated with creating a reusable, domain-independent intelligent tutoring framework are large, but the benefits are also large. In the current state, GIFT can be used by subject matter experts (SMEs), instructional designers, and instructors to create ITSs to meet their needs. As GIFT continues to develop the authoring, instructional, and evaluation processes will continue to improve. Over the past five years great strides have been made in solving the challenges associated with domain-independent adaptive tutoring, and we anticipate progress will continue in the future as GIFT is applied in both military and civilian task domains.

ACKNOWLEDGMENTS

The authors wish to recognize the considerable contributions of the entire ARL adaptive training research team along with their major roles in the development of GIFT: Michael Boyce (adaptive tactile environments and motivation modeling); Keith Brawner (lead for adaptive architecture and machine learning); Benjamin Goldberg (GIFT co-creator, lead for instructional management, and adaptive marksmanship); Gregory Goodwin (lead for individual learner modeling, training effectiveness measures); Michael Hoffman (GIFT software development); Joan Johnston (lead for effectiveness evaluation tools and methods, and team tutoring); Jong Kim (adapting GIFT for psychomotor tasks); Rodney Long (lead for authoring tools, social media, and adaptive MOOCs); Jason Moss (workload measures and training effectiveness); Scott Ososky (authoring tool development and usability evaluations); Anne Sinatra (lead

for team modeling); and Robert Sottolare (GIFT co-creator, ARL adaptive training lead, and domain modeling lead).

REFERENCES

- Boneu, J. M. (2011). Survey on Learning Content Management Systems. In Content Management for E-Learning (pp. 113-130). Springer New York.
- Butler, D. L., & Winne, P. H. (1995). Feedback and self-regulated learning: A theoretical synthesis. *Review of educational research*, 65(3), 245-281.
- Dabbagh, N. (2005). Pedagogical models for E-Learning: A theory-based design framework. *International Journal of Technology in Teaching and Learning*, 1(1), 25-44.
- Goldberg, B., Sinatra, A., Sottolare, R., Moss, J., & Graesser, A. (2015). Instructional Management for Adaptive Training and Education in Support of the US Army Learning Model-Research Outline (No. ARL-SR-0345). ARMY RESEARCH LAB ABERDEEN PROVING GROUND MD HUMAN RESEARCH AND ENGINEERING DIRECTORATE.
- Goodkovsky, V. (1996, June). Intelligent Tutor: Shell, Toolkit & Technology. In Workshop on Architectures and Methods for Designing Cost-Effective and Reusable ITSs, Third International Conference on Intelligent Tutoring Systems, Montreal, Canada, <http://www.goodkovsky.org/IT-STT.htm>.
- Goodwin, G., Johnston, J., Sottolare, R., Brawner, K., Sinatra, A., & Graesser, A. (2015). Individual learner and team modeling for adaptive training and education in support of the US Army Learning Model: Research Outline (No. ARL-SR-0336). ARMY RESEARCH LAB ABERDEEN PROVING GROUND MD HUMAN RESEARCH AND ENGINEERING DIRECTORATE.
- Johnston, J. H., Goodwin, G., Moss, J., Sottolare, R., Ososky, S., Cruz, D., & Graesser, A. (2015). Effectiveness Evaluation Tools and Methods for Adaptive Training and Education in Support of the US Army Learning Model: Research Outline (No. ARL-SR-0333). ARMY RESEARCH LAB ABERDEEN PROVING GROUND MD HUMAN RESEARCH AND ENGINEERING DIRECTORATE.
- Kulik, J. A. (1994). Meta-Analytic studies of findings on computer-based instruction. In E. L. Baker and H. F. O'Neil (Eds.), *Technology Assessment in Education and Training* (pp. 9-33). Hillsdale, NJ: Lawrence Erlbaum Associates.
- Merrill, M.D. (1994). *The descriptive component display theory*. Englewood Cliffs (NJ): Educational Technology Publication.
- Ososky, S., Sottolare, R., Brawner, K., Long, R., & Graesser, A. (2015). *Authoring Tools and Methods for Adaptive Training and Education in Support of the US Army Learning Model: Research Outline*. Army Research Laboratory (ARL-SR-0339).
- Patil, A. S., & Abraham, A. (2010). Intelligent and Interactive Web-Based Tutoring System in Engineering Education: Reviews, Perspectives and Development. In F. Xhafa, S. Caballe, A. Abraham, T. Daradoumis, & A. Juan Perez (Eds.), *Computational Intelligence for Technology Enhanced Learning. Studies in Computational Intelligence* (Vol 273, pp. 79-97). Berlin: Springer-Verlag.
- Sottolare, R.A., Brawner, K.W., Goldberg, B.S. & Holden, H.K. (2012). The Generalized Intelligent Framework for Tutoring (GIFT). Concept paper released as part of GIFT software documentation. Orlando, FL: U.S. Army Research Laboratory – Human Research & Engineering Directorate (ARL-HRED). Retrieved from: https://gifttutoring.org/attachments/152/GIFTDescription_0.pdf
- Sottolare, R., Sinatra, A., Boyce, M., & Graesser, A. (2015). Domain Modeling for Adaptive Training and Education in Support of the US Army Learning Model-Research Outline (No. ARL-SR-0325). ARMY RESEARCH LAB ABERDEEN PROVING GROUND MD HUMAN RESEARCH AND ENGINEERING DIRECTORATE.
- Sottolare, R.A., Burke, C.S., Salas, E., Sinatra, A.M., Johnston, J.H. & Gilbert, S.B. (2017, *in press*). Towards a Design Process for Adaptive Instruction of Teams: A Meta-Analysis. In R. Sottolare, A. Graesser, J. Lester

& R. Baker (Eds.) Special Issue: Generalized Intelligent Framework for Tutoring (GIFT): Creating a stable and flexible platform for innovations in AIED research. *International Journal of Artificial Intelligence in Education*.

VanLehn, K. (2011). The relative effectiveness of human tutoring, intelligent tutoring systems, and other tutoring systems. *Educational Psychologist*, 46(4), 197-221.

Vinsonhaler, J. F. & Bass, R. K. (1972). A summary of ten major studies on CAI drill and practice. *Educational Technology* 12: 29-32.

Wulfeck II, W. H. (2009, July). Adapting instruction. In *International Conference on Foundations of Augmented Cognition* (pp. 687-695). Springer Berlin Heidelberg.

U.S. Army Training & Doctrine Command (TRADOC). (2011). 525-8-2 The US Army Learning Concept for 2015. Washington, DC: Department of the Army.

ABOUT THE AUTHORS

Dr. Robert Sottolare leads adaptive training research within ARL's Learning in Intelligent Tutoring Environments (LITE) Lab and is a co-creator of the Generalized Intelligent Framework for Tutoring (GIFT). He is also ARL's technical lead for the Center for Adaptive Instructional Sciences (CAIS) under ARL's Open Campus Initiative.

Dr. Keith Brawner leads the architecture and ontology research vector within ARL's Adaptive Training team. He is a co-creator of the Generalized Intelligent Framework for Tutoring (GIFT) and his research interests include semi-supervised machine learning techniques.

Dr. Anne Sinatra leads the team modeling research vector within ARL's Adaptive Training team. Her background is in Cognitive and Human Factors Psychology, and her research interests include education, the application of cognitive psychology techniques to the improvement of learning outcomes, and team tutoring.

Dr. Joan Johnston is an ARL Senior Scientist and leads the Science and Technology Objective for Simulation Training Effectiveness. Her background is in Industrial and Organizational Psychology and her primary research interests have been team performance measurement, team training, and decision making under stress.